

U5 SL-300/10 POMPĂ CENTRIFUGALĂ MULTIETAJATĂ VERTICALĂ

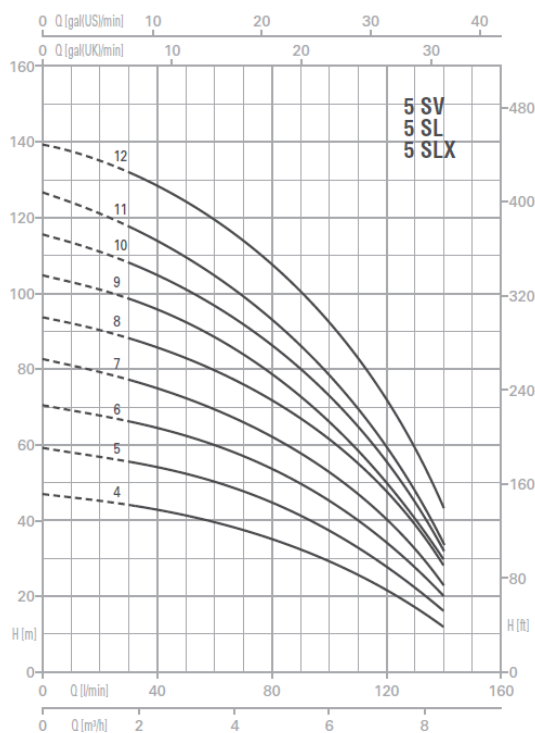

Putere absorbită P1:	2,67 kW
Putere P2:	2,2 kW
Alimentare:	230 V (50 Hz)
Înălțime de refulare max.:	114.2 m
Debit max.:	8400 l/h
Diametru de aspirație:	1"1/4G
Diametru de refulare:	1"1/4G
Numar de etaje	10



Debit Q (m ³ /h – l/min)							
0	1.8	2.4	3.6	4.8	6	7.2	8.4
0	30	40	60	80	100	120	140
Înălțime de refulare H (m)							
144.2	106.4	102.9	95.2	85.2	72	53.3	30

Temperatura maximă lichid:	110 °C
Carcasă pompă:	fonta
Suport motor:	fonta
Rotor pompă:	inox AISI 304
Etanșare mecanică:	grafit – carbură de siliciu
Etanșare corp pompa:	EPDM
Clasă de izolație:	F
Clasă de protecție:	IP44
Protecție termică:	Da

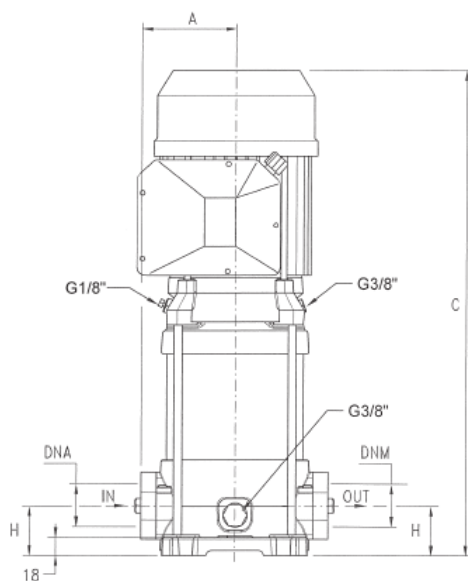
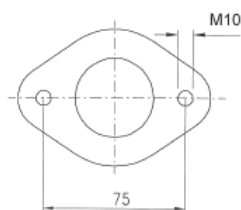
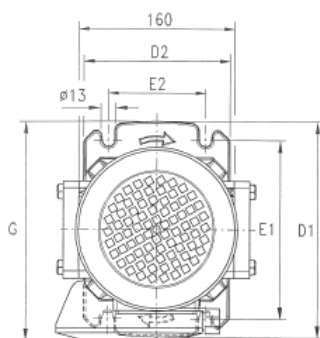

ULTRA 5SL / SLX	DIMENSIONS (mm)								Kg		DNA	DNM
	A	C	D1	D2	E1	E2	G	H	SL	SLX		
U 5SL / SLX -120/4	98	405	220	150	180	100	221	50	20,7	21,5	1"1/4G	1"1/4G
U 5SL / SLX -150/5	98	459	220	150	180	100	228	50	23,7	22,2		
U 5SL / SLX -180/6	98	483	220	150	180	100	228	50	24,9	23,4		
U 5SL / SLX -200/7	98	507	220	150	180	100	228	50	27	25,5		
U 5SL / SLX -250/8	98	531	220	150		100	228	50	28	26,4		
U 5SL / SLX -280/9	98	M 600	220	150	180	100	M 236	50	30,8	29,2		
		T 555					T 228					
U 5SL / SLX -300/10	98	M 624	220	150	180	100	M 236	50	31,4	29,9		
		T 579					T 228					
U 5SL / SLX -350/11	98	648	220	150	180	100	236	50	34,7	33,2		
U 5SL / SLX -380/12	98	672	220	150	180	100	236	50	35,4	33,9		